

PRONAF PLAN FOR CIUDAD JUAREZ: INTERNATIONAL CROSSING OF PLANNING MODELS AND URBAN TRANSFORMATION

Marisol RODRIGUEZ, Prof.

Ciudad Juarez Autonomous University, Mexico
marisol.rodriguez@uacj.mx,

Hector RIVERO, Prof.

Ciudad Juarez Autonomous University, Mexico
hrivero@uacj.mx

ABSTRACT

In the 1960s, the Mexican government promoted, through the National Border Program - ProNaF (Programa Nacional Fronterizo), a regional and urban planning initiative to face an economic openness in the northern border cities which aimed to detonate an integrated development model. Mexican architect Mario Pani and Taller de Urbanismo, drawing on the ideas of major interventions already operated in Mexico City, especially the Mexico's National University urban project (UNAM), developed the urban plans. As part of this program, was proposed the first urban plan for Ciudad Juarez that incorporated a global economic vision, and was built between 1962-1963 a modern urban center known as Zona ProNaF, which proposed to lay out the foundations for the modern city. A particularly interesting aspect is the developers concern to work with an "urban border proposal", considering it as a transitional space between the American city and the Mexican city, an urban center that will establish the primary gateway to a new international border crossing between the two countries. Based on emerging international planning concepts, the ProNaF plan introduced three main elements of urban transformation. The establishment of a modern urban aggregation system, which consists of a superblock and a specialized and efficient road system, was the main element in the process of morphological transformation. From here, there will be two basic strategies for shaping the city: the introduction of a civic center and an interpretation of the neighborhood units, defined by the "fraccionamientos" (neighborhood divisions). These two urban elements do not necessarily correspond to the fundamentals and principles established by the Modern Movement, but to the Anglo-Saxon urban tradition. The introduction of the superblock profoundly influenced the city's urban form, dominated by the traditional street grid, and implied the efficient city elements arrangement for a new urban life scale. The construction of a civic center, figured as the main component for community life. This neighborhood planning proposes a residential area, predominantly pedestrian, with a small central core. Thus, the city consists of the union of small and complete parts, seeking, at another scale, for the repetition of the city urban structure. The discussion submitted proposes a ProNaF - Ciudad Juarez study, analyzing three main elements of urban transformation in the planning history: the attempt to introduce the superblock, the civic center and the neighborhood unit.

INTRODUCTION

During the first half of the 20th century there were established the conditions that allowed the emergency and institutionalization of urban planning in Mexico. The Mexican urban history is very antique and characterized by the juxtaposition of visions of the world and society of pre-Hispanic and Hispanic cultures. However, the modern urban planning, understood as the urbanism practice originated in Europe and the United States in the 19th century as an answer to the necessities imposed by the industrialization, began to develop in Mexico in the first half of the 20th century. The modernity models of the more industrialized nations began to be used in order to promote the economic development of the country and construct the image of a modern republic. In the 1940s, the growth and diversification of the Mexican economy, resulting from increased industrial activity exacerbated during the Second World War, promoted an economic dynamism that transformed the face of the country, changing from predominantly rural to urban in a few years (Meyer, 2000: 883).

The 1950s were marked by the growing importance of the the United States as a cultural and economic reference. The American modernity, considered the fourth major cultural revolution in Western civilization, which identifies the 20th century as the "American century" emerged as a new paradigm of modernity that unlike

earlier, did not emerge in European culture (Cantor, 1997). On the other hand, through the policy of “Good Neighbour” the attempt to establish strong ties with Latin America opened the possibility of a number of governmental and private initiatives in several fields. Mexico, after estrangements due to historical, geographic and cultural conflicts, began to focus on the economic development reached by its northern neighbor, as well as its image of urban modernity.

The practice of urban planning began to arrive in Mexico with regional economic development strategies similar to those used in the United States since 1930s. In particular, the ones promoted by the Tennessee Valley Authority, which expressed the attempt to improve the living conditions of one of the poorest areas of that country through a set of strategies focused on potentiate the characteristics of the region and articulate industrial and rural development. To face the phenomenon of urbanization and regional disparities, in the 1950s, the Mexican government began to promote the use of regional planning as a modern and internationally accepted instrument to foster the economic development not only for the central area, but also in the south and north regions of the country. The need to improve port and tourism infrastructure was a priority for the development of regional planning studies such as the Regional Plan for Yucatan (1951) and the Regional Plan of Acapulco (1952). Under the same development strategy was created in the 1960s the National Border Program (Programa Nacional Fronterizo, known by its acronym ProNaF).

On January 10, 1961, was instituted this program during the Presidente Adolfo Lopez Mateos government (1958-1964) to improve the development of the northern states, different from the rest of the country by its borderland condition with the United States. The ProNaF’s initiative can be understood as an effort to transfer to Mexico the model of the American modernity. This was expressed in 1966 by Antonio Bermudez, the Director of the program: “the way the United States has reached its economic greatness, on which depends its military strength and its social and cultural development, is precisely what we Mexicans should bear in mind as an example, we should imitate” (Bermudez, 1966: 19). The federal government sought to establish a regional planning proposal to potentiate the economic advantages of being neighbor to the country with the highest purchasing power, especially seeking the development of tourism and the increase in Mexican exports. Since the 1940s, the tourism became a very important economic activity in Mexico, accounting for more than fifty percent of the value of goods exports (Meyer, 2000: 889). The northern border states represented the region with greatest impact on the growth of tourism activity. Through those states arrived at the country 68 million people in 1959, and in 1960, of the 670 million US Dollars of national income from tourism, 520 million were related to the border region (Programa Nacional Fronterizo, n.d.[1960s]: n.p.).

At the same time, urban problems and social contradiction became more acute in these border cities. Therefore, it was urgent to establish direct and modern connections with the neighboring American cities and consolidate a production and trade network able to absorb the purchase power of that country. Two factors were key: tourism and industrialization. The border cities were seen as the best showroom where could be display the Mexican goods and a strategic point to establish modern amenities to attract family tourism. As part of the ProNaF, was instituted the Mixed Committee on Border Urban Development (*Comisión Mixta de Desarrollo Urbano Fronterizo*), through which were elaborated the so called Regulatory Plans (*Planes Reguladores*), master urban development plans for several cities in the northern Mexican border: Ensenada, Tijuana, Nogales, Mexicali, Piedras Negras and Ciudad Juarez.

Renowned Mexican architect Mario Pani (1911-1993) was the chief architect of the National Border Program (ProNaF) and Domingo Garcia Ramos (1911-1978) participated as a member of the Technical Council of Regional Planning (*Consejo Técnico de Planeación Regional*). Garcia Ramos was also chief of the ProNaF’s plans of Ciudad Juarez, being the main author of the Draft Regulatory Plan (1958) and the final Regulatory Plan (1962). Pani and Garcia Ramos are considered as one of the first Mexican urban planners, as well as pioneers in the transfer of CIAM’s ideas of modern urban planning to the Mexican planning practice. Both were members of *Taller de Urbanismo*, a group of architects and planners founded in 1945 that introduced in Mexico new planning ideas through major urban projects: Nonoalco-Tlatelolco residential complex, the Ciudad Satelite neighborhood unit, the UNAM’s University City Complex; as well as in several regional studies.

Ciudad Juarez was the city that received more technical and financial attention under the ProNaF and where the urban solutions had a symbolic meaning of national dimensions. Those proposals incorporated to the city a portion of land, known as El Chamizal, that the United States returned to Mexico in 1963 (it was in legal dispute over a century). This portion of urban land received great attention in the ProNaF's Regulatory Plans and the propositions began to be effective in 1962, materializing a new urban nuclei and an international crossing that established the most significant morphological transformation on the city's urban history in the 20th century. The urban intervention in ProNaF Zone, as it is known, lay out the foundations for a modern city, defining the first transition step from monocentric towards multicentric city, establishing a new urban life scale and a transcultural urban form.

In terms of the Mexican's planning history, these plans are notable examples of what can be considered as the first generation of Mexican modern urban planning, characterized by the transfer of international models and theories that deeply influenced the definition of the possible modernity in the Mexican conditions. The transfer of ideas and urban models is an area of urban planning history that address the need of understanding the circumstances in which an idea is applied in a different context from the one it emerged (Hall, 1996). In the case discussed in this paper, that is to say, the ProNaF's Regulatory Plan for Ciudad Juarez (1958-1962), this issue is relevant for three particular reasons. First, it is a Latin American city located in the United States-Mexico border and the plans were developed when that neighbor country was a great reference of urban and economic modernity. Second, it is a turning point in the history of urban planning characterized by the international crossing of theories and also by the dissolution of CIAM and the inauguration of Brazilia. Thirdly, the plans were elaborated by renowned Mexican architects that belonged to a generation inspired by the CIAM's urban ideas and also Anglo-Saxon theories, which they used to build a vision of the future Mexican cities. In that sense, this paper addresses the impact of the transfer or circulation of urban planning models in the urban transformation of Ciudad Juarez under the ProNaF plans. To study the issue of transfer or circulation of planning ideas, we rely on the understanding of urban plans as representations of the city, notion that refers to the concepts and systems of ideas utilized to define, design and make the city by the several social actor like the dominant classes, professional elites, inhabitants (Roncayolo, 1990: 160-162 and 2001: 268-269). This notion underlies to the possibility of study the representations of the city from those who make the city and from those who inhabit the city, what has been indicated as an approach for urban cultural history that invites to consider the urban proposals, ideals and also the imaginaries and desires of the society (Pesavento, 1995).

SUPERBLOCK VERSUS AMERICAN FREEWAY, THE URBAN CELLS AND THE REDEVELOPMENT OF THE CITY

The introduction of the superblock as a new urban aggregation system was one of the main elements of urban transformation on ProNaF's Regulatory Plans of Ciudad Juarez. The implementation of a metropolitan unit between the Mexican Ciudad Juarez and the American El Paso¹ was a fundamental point in the solutions proposed by the ProNaF's urban plans (1958, 1962). As in the first Ciudad Juarez's master plan developed by architect Rafael Mijarez in early 1950s - antecedent of ProNaF plans -, road connectivity between the two cities was essential to achieve this unity, based on an international circuit connected to the border bridges. This become more important in 1958 when was proposed a freeway for the American city of El Paso that would allow to incorporate the neighborhood units, often dispersed from each other. In the Mijarez's plan of Ciudad Juarez, the introduction of a direct freeway to the United States was more important than the rearrangement of Ciudad Juarez, limited to an indication of functional areas, evidencing a denial of the city. However, in the plans developed by Domingo Garcia Ramos under ProNaF, the zoning and the freeway were not the core elements. The circulatory system was a connector element between the parts of the existing cities and sought the hierarchy of roads (pedestrian and vehicular) as defined by CIAM, but never seeking to incorporate the American freeway. The challenge of an Integration Plan of Ciudad Juarez - El Paso Metropolitan Area demanded the joint

¹ In the late 1950s, Ciudad Juarez, founded in 1659, and El Paso founded in 1850s, had virtually the same population, however, El Paso was more extensive in size.

of the Ciudad Juárez's compact and monocentric fabric with the extended urban development of El Paso city (occurred throughout the border). The 1958 Ciudad Juárez Draft Regulatory Plan, proposed the city extension over the Juárez Valley' agricultural fields, using neighborhood units distanced 1.5 to 2 km between each other, leaving agricultural areas among them (Figure 1).



Figure 1. Draft Regulatory Plan, 1958. In green the future neighborhood units, in red a government center. Municipio de Ciudad Juárez. (1958) (colors added by the authors).

In the final Regulating Plan (1962), this proposal was replicated through the new residential zones over agricultural fields to the east in “self-sufficient neighborhoods units” conformed by superblocks (1600 to 2000 inhabitants by superblocks), with communal services in civic and commercial centers: elementary school, daily commerce, green areas (Figure 2). The emphasis was on defining the possible modern city in Ciudad Juárez and the roadways were a part of the aggregation system. These concept guides the urban expansion and transformation and is based on the idea of “urban cells” defended by Pani and Taller de Urbanismo. The most significant elements in term of morphological transformation, is the crossing between urban planning models introduced in the CIAM's superblock and the Anglo-Saxon neighborhood unit. The “urban cells” sought to establish a new model that could be apply to both, the transformation of existing urban areas and the urban expansion.

Basis of many of the Taller de Urbanismo's projects in other Mexican cities, the “urban cells” sought to transform, through the superblock, the traditional block 100 meters long (with plots between 200 and 500 square meters) that characterized the historical growth of Mexican cities. It proposed the aggregation of all plots of a traditional block in a large plot of 10.000 square meters (one hectare), which articulated with others, reaching a maximum of six plots, will shape an urban cell. Pani explained it this way: “...the aggregation of plots of 10.000 square meters, would allow with a maximum intensity of six times, building 60.000 square meters, so we would get 3.000 square meters of gardens in each plot of one hectare...” (Pani, cited in Iannini, 1999: 31). It shares with the CIAM's superblock the proposal to reduce the number of vehicular crossing and to separate vehicular and pedestrian circulation, an idea that Le Corbusier advocated since 1925, in his book *Urbanisme*.

The CIAM's superblock was a fundamental element in the design of Brasília, Brazil's new capital city inaugurated in 1960, at the end of Juscelino Kubitschek's presidential government (1956-1961), that may have been an example of modernization and public development for the Mexican President Adolfo López Mateos (1958-1964). In Brasília, the superblock established a new urban form and way of life, although on a different strategy, which sought the creation of a new city, not the reorganization of existing cities as in the case of the ProNaF Plans. The CIAM's proposal to reduce the number of vehicle crossing and the separation of pedestrian and vehicular traffic was a central element, present in both cases.

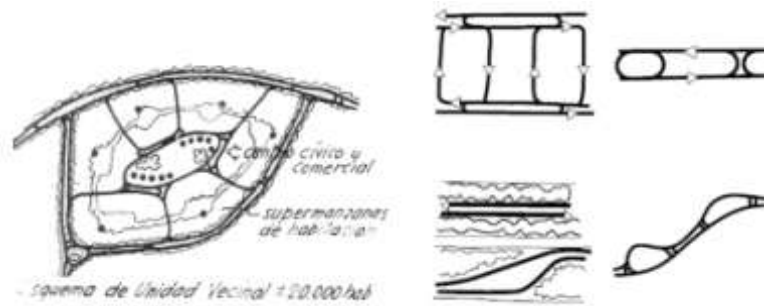

Figure 3. Garcia Ramos's outlines of the neighborhood unit (left) and Herrey's road system (right), showing the incorporation of Acequias with winding streets.

A housing superblock is equivalent to 400 meters side square (optimal distance proposed by Le Corbusier's Plan Voisin between bus stops), with an area of sixteen hectares and a perimeter of one mile. The "neighborhood units" will be surrounded by a road system ensuring the smooth flow of vehicles, based on the continuous and rotary Herrey system of Viennese architect Herman Herrey (1944), that will also shape the urban unit. (Figure 4).

The residential areas called *fraccionamientos* (divisions), as the neighborhood unit, are the "urbanization element" that will operate in Ciudad Juarez since the establishment of the 1962 Regulating Plan. Mario Pani introduced in Mexico a condominium law proposal in 1956, precedent of the idea of the "fraccionamientos"³. This is the Taller de Urbanismo's reading of the neighborhood unit as the American's garden city interpretation, especially of Radburn, Clarence Stein and Henry Wright's New Jersey 1928 project. As in Radburn, *Taller de Urbanismo* uses the superblock, the parks as the project backbone and the specialized circulations with the separation between pedestrian and automobiles traffic.

If modernity arrives to Mexico with the transfer of an economic model, it also arrives with another daily life, a new *Life Style*, related mainly to the American city features, among them the suburb and the automobile. *Ciudad Satélite* (Estado de México, 1954), is the *Taller de Urbanismo*'s "city outside the city" proposal, and represents the Mexico's change of paradigm, from the "barrio" to the American suburb, "is the promise of a modern consumer society, that receives its cultural standards from the United States" (Krieger, 2006: 211). The ProNaF's urban plans for the border cities within the United States, express the search for another life style. Outside the compact and dense traditional city, another city is considered; a new extended, blurred and flexible city.

³ In Guadalajara "the Urban fraccionamientos law" appears in 1953, in the Estado de Mexico appears in 1958.



Figure 4. Ciudad Juarez - El Paso Integration Plan, 1962. In green the urban cells associated to the 1958's neighborhood units surrounded by parways along the Acequias. In dark gray the governmental center and ProNaF Commercial Center. COMDUF, 1962.

The idea of “urban cells” proposed the possibility of reproduction and transformation of the urban fabric from neighborhoods in a biological analogy that underlies the definition of two characteristic areas: a peripheral zone and a core or inner zone. These aggregation units will allow a greater functional autonomy for the development of community life, and in this sense, expresses a relation with the proposal from earlier decades of the neighborhood units. The neighborhood becomes the unity of urban transformation that allow the construction and transformation of the modern city. In this sense, the proposal moves away from the functional conception of the Athen’s Chart and can be placed on the theoretical line of post-war CIAM, characterized by the criticism of the rigidity and abstraction of the functional city and the crossing of CIAM’s and Anglo-Saxon urban theories to the possibilities of the modern city.

A NEW URBAN CENTER, THE TRANSFORMATION TOWARDS A TRANSCULTURAL URBAN MORPHOLOGY

The ProNaF Ciudad Juarez Regulating Plan attempt to separate or negate the existing old city, understood as complex, declining and nonfunctional. In the ProNaF, “other” spaces for political and cultural representation and “other” centrality system are considered. These are one of the most significant proposals of the 1958 and 1962 plans. The necessity to establish a direct connection with El Paso, the American neighbor, is a main element of the Ciudad Juarez-El Paso Metropolitan Area Integration Plan and justifies the city functional displacement to the east of the existing center, towards not developed lands. The 1962 Regulating Plan proposed the location of a new and modern international border crossing to which it is associated the creation of a new tourist and commercial urban center (services, commerce, hotels and tourist facilities). Also proposed the transfer of the political functions, from the existing center to a new civic and government center, locating in the intermediate geographic point between the new and the old city (see Figure 3). This new center must be a formally significant space. For Garcia Ramos and Pani, “the monumental character is what makes the differences between the public administration buildings from those other destined to private offices” (Garcia Ramos, 1973: 187).

The tourist and commercial urban center constructed in 1962 gave rise to a new centrality that brought out the Ciudad Juarez greater 20th century urban transformation, establishing the first step in the transition from a monocentric to a multi-centre urban structure, process already consolidated. The emphasis was put in another type of “center”, a “commercial center”, different from the CIAM civic center, which is justified considering two particular aspects. First, the privileged

position, next to the new city and country front door, transforming the new center into the ideal showroom for the Mexican product exhibition and tourism attraction. Second, the ProNaF policy of concentrate the economic resources in the construction of “commercial centers”, as the main transformation detonators of the existing cities. The ProNaF Commercial Center finally constructed is a group of buildings with a pedestrian path, set in a superblock surrounded by the Herrey system road, and connected with other future city “cells”. It is assumed that the modern city is made up of the addition of functionally complete and well done parts.

The new representative nucleus of the modern Ciudad Juarez is far from every slum and obsolete structure of the traditional city and near from the new façade for Mexico, toward the United States. There is clear intention to leave out the street-commerce scheme and the mixture of uses of the old city. All-type services are concentrated in a single “urban cell”, surrounded by a parking lot. The tourists will not visit the “old city”. The objective is to create a new scene of modernity, a new urban life scale (Figure 5). The buildings in this commercial center constitute the city’s representative landscape and is understood as the most important instrument of the city transformation. Antonio Bermudez, ProNaF’s Main Director, comments in 1966: “Now it feels a big spirit, a safe consciousness and a legitimate pride, since those buildings, example of our architecture, message of our border population’s overcoming and dignity, are a permanent, solid example, of actual Mexico: progressive, dynamic, working, with faith in itself” (Bermudez, 1966: 136).

Nevertheless, as in UNAM’s University City (Mexico 1946-1953), the important elements of the project are not only “the parts”, but also “the group impression”, the group is a collective fact. In the project’s extreme west, the cultural zone settles down with subtle reminiscences of the region’s pre-Hispanic architecture, like the ones used in the Pedro Ramirez Vazquez’s Art and History Museum building (Figure 6), or in the Enrique de Moral’s Crafts Market building. In the east part of the project, the Camino Real hotel was inspired by the convent and *haciendas* (farms) architecture, first of many Ricardo Legorreta’s hotels. To the center is represented the most modern Mexico, with an exhibitions and convention hall that retakes Felix Candela’s parabolic building forms. All the strolls generated between these buldings are accompanied by a linear commerce development and green spaces, designed by the Mario Pani’s architecture office. Within this commercial infrastructure, the first and greater border supermarket was constructed. The new urban form defined by the superblock established the deeper morphological transformation processed in Ciudad Juarez during the 20th century (Figure 7).



Figure 5. Aerial imagen of ProNaF’s Commercial Center in construction in the 1960s.
Anonymous author.



Figure 6. Exhibitions and convention hall. ProNaF's Commercial Center in construction in the 1960s. Anonymous author.



Figure 7. Aerial imagen of Ciudad Juarez, 2007. In red the ProNaF superblocks, showing the morphological change compared to the traditional urban fabric. Note the road direct connection with El Paso city. Scheme made by author from Google Earth's Digital Image.

PRONAF PLAN OF CIUDAD JUAREZ (1958-1964) AND THE ORIGINS OF MEXICAN URBAN PLANNING

In the ProNaF's Regulatory Plans of Ciudad Juarez, two city visions coexist: the modern functional perspective, in which the city is hierarchically organized; and the American city planning practice in which the city disperses. Two urban practices or intervention strategies also coexist: the modern city one, focused in finding the model's implantation mechanisms, and the Anglo-Saxon urban planning, where the city is a part of a region. The international crossing of urban planning models is present in the urban transformations operated with the construction of ProNaF Commercial Center in the 1960s, the only materialized fragment of the ProNaF's plans - the new 1964 Mexican government did not assign resources to continue this program. The "shopping center" of the American culture is used for the sale of Mexican goods, but not as part of an anonymous suburb; it is self-contained in a superblock, isolated from other uses and "polluting" factors, with free automobile transit nucleus as the CIAM modernist urbanism defined. The emphasis given to the urban center expresses the debate that characterized the CIAM in the 1950s. Nevertheless, the integration of this subject in the CIAM's agenda is an expression of the presence of Anglo-Saxon theories and ideas. As noted by Eric Mumford, from the American vision, in 1940 Lewis Mumford mentioned the lack of consideration in CIAM's theories of the political, educational and cultural functions, what was a detonator to regard the importance of the center in the CIAM's modern city program (Mumford, 2000: 133, 142). Also important was the role of the MARS English group in defining the importance of the theme of the core of the city for the discussions at 8th CIAM (Mumford, 2000: 203).

The ProNaF Regulating Plans analysis confirms that the Mexican urban planning arises in a complex context, where three main aspects seem to have greater relevance. First, the presence of a favorable atmosphere for architecture and urban planning after Second World War, which promoted urban planning as a strategy for the economic development and modernization of Mexico. Secondly, coincided with the consolidation of the United States as a western world power, associated to a new life model spread through the cultural construction of “the American way of life”. Thirdly, it is associated with the 1940s thru 1960s period, in which the transfer of CIAM’s theories to Latin America experienced its greater effervescence. It is in this context, that the Mexico’s early urban planning experiences is understood, as well as the Ciudad Juarez Regulating Plans under ProNaF. They must be considered not only as an important chapter of the beginnings of urban planning in Mexico, but also as an indelible mark in the city’s urban transformation⁴.

REFERENCES

- Benevolo, Leonardo. (1977). La proyectación de la ciudad moderna. Barcelona: Gustavo Gilli, 3th edition, 2000.
- Bermudez, Antonio. (1996). El rescate del Mercado Fronterizo. Mexico: Eufessa.
- Cantor, Norman F. (1997). The American Century. Varieties of Culture in Modern Times. HarperCollins.
- COMDUF. Comision Mixta de Desarrollo Urbano. (1962) Plano Regulador Cd.Juarez. COMDUF, Chih.
- Garcia Ramos, Domingo. (1973). Iniciación al Urbanismo. México: UNAM, 1th edition, 1961.
- Hall, Peter. (1996). Ciudades del mañana: historia del urbanismo en el siglo XX. Barcelona: Ediciones del Serbal. (1rs edition 1988)
- Iannini, Humberto. (1999). “Introduction” In: Universidad Autónoma Metropolitana. Mario Pani Arquitecto. Mexico D.F., Noriega Editores.
- Krieger, Peter. (2006). Paisajes urbanos. Mexico: UNAM.
- Le Corbusier. (2003) Como concebir el urbanismo. Buenos Aires: Infinito, of the 1rs edition in 1946.
- Meyer, Lorenzo. (2000). “De la estabilidad al cambio”. In: Historia General de México. México: Centro de Estudios Históricos, pp. 882-943.
- Municipio de Ciudad Juarez. (1958). Plano Regulador de Ciudad Juarez. Ciudad Juarez, Chih.
- Mumford, Eric. (2000). The CIAM Discourse on Urbanism, 1928-1960. Massachusetts: The MIT Press.
- Pesavento, Sandra J (1995). “Muito além do espaço: por uma historia cultural do urbano”. Estudos históricos. Rio de Janeiro, vol. 8, n° 16, pp. 279-290.
- PRONAF (n.d.) [1960s probable decade]. Programa Nacional Fronterizo. Mexico D.F.: Programa Nacional Fronterizo, (1960s probable decade).
- Roncayolo, Marcel. (1990). Villes et ses territoires. Paris, Gallimar.
- Roncayolo, Marcel. (2001) [interview in] Lepetit, Bernard. “Os espelhos da cidade: un debate sobre os discurso dos antigos geógrafos”. In: Bernard, Lepetit (2001). Por uma nova historia urbana. São Paulo, Universidade de São Paulo EDUSP, pp. 265-300.

⁴ We thank Leslie V. Valenzuela Flores and Javier Chávez Chávez collaboration in the translation of this article.